

**leboulch**



[www.leboulch.com](http://www.leboulch.com)

# GOLD<sub>2</sub>

**THE TIPPING TRAILER THAT IS  
WORTH ITS WEIGHT IN GOLD!**



**A complete machine with many equipment options possible**

## STANDARD EQUIPMENT



**Folding aluminium ladder, galvanised side mudguards and predispositions for optional equipment** (side bumper and thermoplastic mudguards).

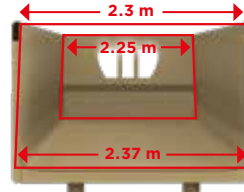

**Tapered body** (2.25 m at the front and 2.3 m at the rear), wider at the bottom than at the top to facilitate unloading.



**Document tube** with individualised parts book and user manual.

**Sturdy 300 x 100 x 10 mm tubular chassis stringer** for the entire range, except for 47S16, 53S16 and 53D19 (300 x 100 x 8 mm).

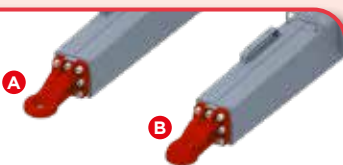

**Choice of eyelets**

- (A) Bolted Ø 50 mm (standard)
- (B) Bolted knee-joint (option)



**Hydraulic folding parking stand** attached directly to the trailer chassis to free the drawbar and facilitate turning.



**Noise-reducing silentblock** for centering and lateral locking of the body on the chassis.





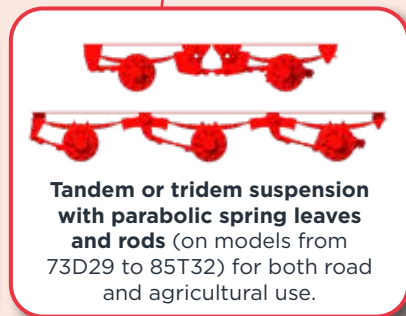
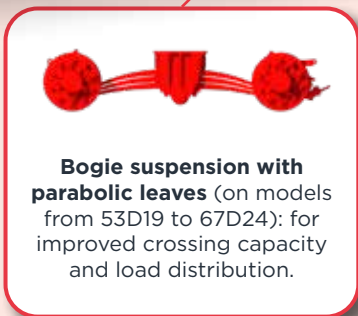
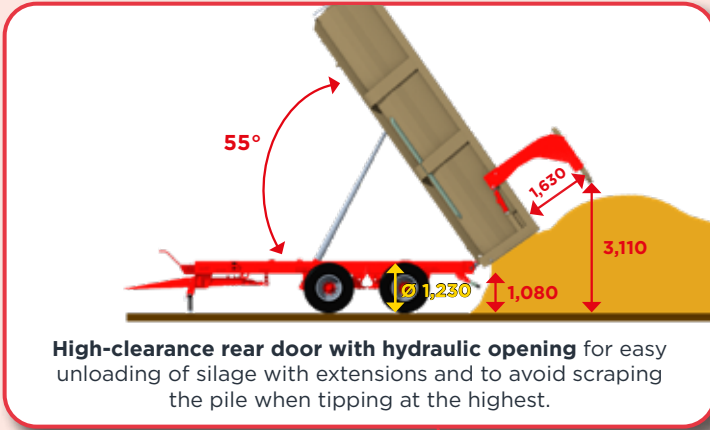



# GOLD<sub>2</sub> XL

- ✓ Single or double axle
- ✓ 16 to 24 tons
- ✓ Sturdy and reliable

# GOLD<sub>2</sub> XXL

- ✓ Double or triple axle
- ✓ 19 to 32 tons
- ✓ High resistance to intensive use

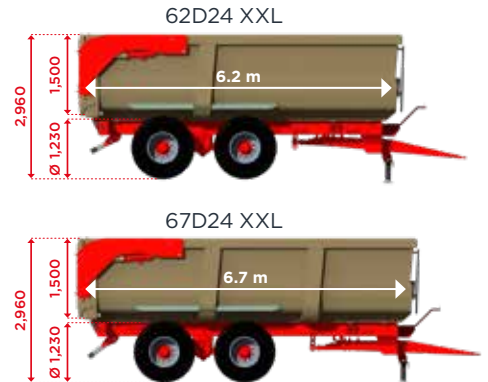
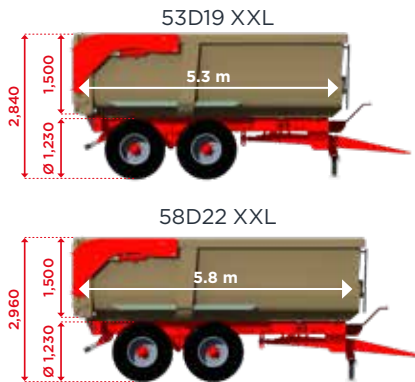
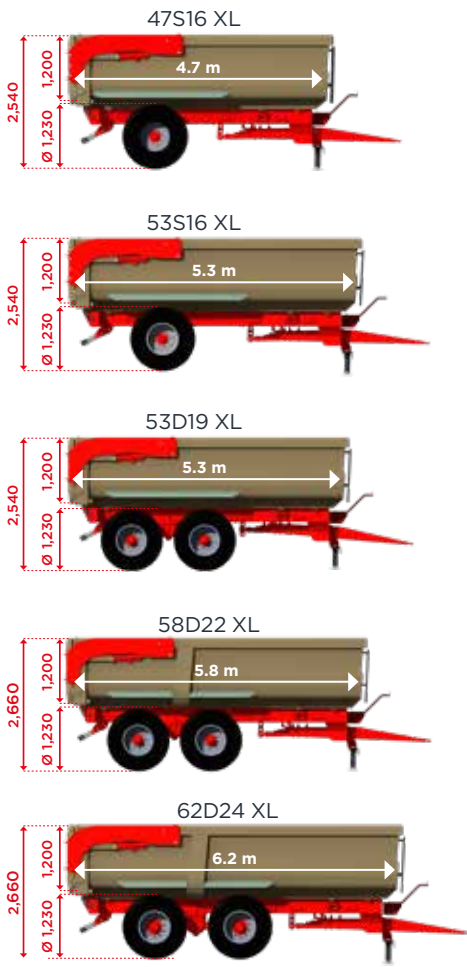

## OPTIONS

**300 mm** (steel or aluminium), **500 mm** (aluminium) or **700 mm** (aluminium) extensions, stackable up to 1 m. 2-part side extensions on single- and double-axle models, and 3-part extensions on triple-axle models.



### Rolling cover

